

Peak flow meter

What is a peak flow meter?

A peak flow meter is a device that measures how well air moves out of the lungs. Many different types of meters are available.

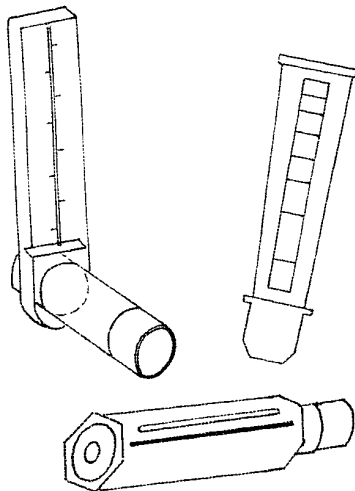

A peak flow meter is used to check your child's asthma, as a thermometer is used to check a temperature. During an asthma episode the airways in the lungs become narrow and the peak flow number may be low, showing that air is not moving easily through the lungs.

Using a peak flow meter can also help you and your child's doctor:

- decide if the Asthma Action Plan is working well
- decide when to add or stop medicine
- decide when to seek emergency care

How should my child use a peak flow meter?

Be sure your child tries to do his or her best every time. The reading you see on the meter depends on your child's effort.

To use a peak flow meter your child should follow these steps:

1. Place the marker at the bottom of the scale.
2. Stand up or sit up.
3. Take a deep breath.
4. Put the meter in the mouth and close the lips around the mouthpiece. Do not put the tongue inside the hole. Do not cover the hole on the back end of the peak flow meter when holding it.
5. Blow out as hard and as fast as possible. Don't cough or huff into the peak flow meter, as this will give a false reading.

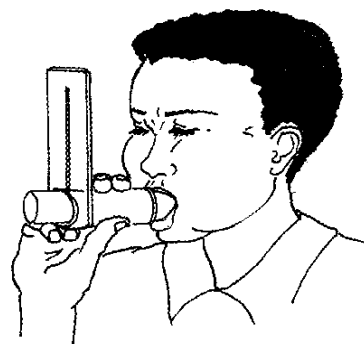

6. Write down the number from the meter.
7. Repeat steps 1 through 6 two more times.
8. Write the best (highest) of the 3 numbers in your child's peak flow diary every day, or as instructed by the doctor.

What should my child's peak flow number be?

Your child's number can be determined from predicted normal peak flow values for people of the same age and height. See the chart at the end of this sheet for average peak flows for healthy children and teenagers.

Your health care professional can also determine your child's peak flow number based on a personal baseline. In this case your doctor will work with you to determine the peak flow numbers.

How does the peak flow zone system work?

Once you know your child's predicted peak flow number, the doctor can use it to help put together an Asthma Action Plan. (See Asthma Action Plan.) The peak flow numbers on the Asthma Action Plan are set up like a traffic light. This will help you know what to do when your child's peak flow number changes.

Green Zone (80 to 100 percent of your child's predicted number) signals all clear. Your child is able to do usual activities and sleep without asthma symptoms such as cough, wheeze, shortness of breath, or chest tightness. Follow the **Green Zone** plan.

Yellow Zone (50 to 80 percent of your child's predicted number) signals caution. Your child has warning signs of an asthma episode that may include cough, wheeze, shortness of breath, chest tightness, or runny nose. Your child may have trouble sleeping through the night. Follow the **Yellow Zone** plan.

Red Zone (less than 50 percent of your child's predicted number) signals an emergency. Your child may have signs of difficult breathing, retractions (skin sucking in with each breath), trouble walking or talking, or the medicines may not be working. Follow the **Red Zone** plan.

When should I call the clinic?

- Your child is in the Yellow Zone for more than 12 to 24 hours.
- Symptoms are getting worse.
- Your child is in the Red Zone.

When should I call 911?

- Your child is having trouble walking or talking.
- Your child's fingernails or lips are blue or gray.
- You are worried about how your child will get through the next 30 minutes.
- Your child stops breathing.

Questions?

This sheet is not specific to your child but provides general information. If you have any questions, please call the clinic.

For more reading material about this and other health topics, please call or visit the Family Resource Center library, or visit our Web site: www.childrensmn.org.

Average peak flow rate for healthy children and teenagers

All tables are averages based on tests with a large number of people, and should be used as a guide only. Peak flows vary with the type of meter used.

Height in inches	Average peak flow	Yellow Zone 50-80% of average peak flow	Red Zone less than 50% of average peak flow
43	147	74 - 118	< 74
44	160	80 - 128	< 80
45	173	87 - 139	< 87
46	187	94- 150	< 94
47	200	100 - 160	< 100
48	214	107 - 171	< 107
49	227	114 - 182	< 114
50	240	120 - 192	< 120
51	254	127 - 203	< 127
52	267	134 - 214	< 134
53	280	140 - 224	< 140
54	293	147 - 234	< 147
55	307	154 - 246	< 154
56	320	160 - 256	< 160
57	334	167 - 267	< 167
58	347	174 - 278	< 174
59	360	180 - 288	<180
60	373	187 - 298	< 187
61	387	194 - 310	< 194
62	400	200 - 320	< 200
63	413	207 - 330	< 207
64	427	214 - 342	< 214
65	440	220 - 352	< 220
66	454	227 - 363	< 227

Source: Polgar, G. and Promadht, V.: *Pulmonary Function Testing in Children: Techniques and Standards*, Philadelphia, WB Saunders Company, 1979.

Children's Hospitals and Clinics of Minnesota
Patient/Family Education
2525 Chicago Avenue South
Minneapolis, MN 55404
7/09 ©Copyright

